



COMMERCIAL HEATING SOLUTIONS



STEEL MULTI COLUMN  
RADIATORS

EDS 670/6 04.09.18

Units 13-14 Charlwoods Road  
East Grinstead, West Sussex, RH19 2HU  
[www.clyderadiators.co.uk](http://www.clyderadiators.co.uk) 01342 305550

A brand of IRSAP, Italy's leading manufacturer of design led radiators.

# Contents

Clyde is a brand of the IRSAP, Italy's leading manufacturer of design led radiators. With over 50 years experience, we have the expertise to produce the best in quality & customer service.

Clyde provides bespoke solutions for LSTs, Cast Iron, Multi Column and Aluminium radiators. With a wide range of traditional and contemporary radiators, Clyde's solution based approach is designed to ensure we supply the ideal solution for all commercial and industrial requirements.

Our dedicated team of technical advisors and estimators will discuss your installation including the calculation of your heat output requirements (from drawings if necessary), arrange a full quotation based on your exact project specifications and provide lead times. They can also arrange a site visit from our National Sales Network if required.

For more information about Clyde or any of our products, please contact our customer service department: 01342 305522 / 305566

Key Features & Technical Data	4-5
Section Emission Rates	6-7
Quick Sizing Charts	8-13
Fixing & Enclosures	14
Connections & Carrying Radiators	15
Finishes & Valves	16-19

# Tesi

Our Tesi steel multi column range is made in our factories in Italy and is the largest in the UK market. A huge 500,000 sizes can be achieved by combining column depth, height and number of sections. Finished as standard in White RAL 9016 or in a choice of 25 RAL colours, 32 special finishes & lacquer, please specify at time of order.

## KEY FEATURES

- 2 - 6 Column options in up to 54 sections made to order
- 25 Heights; 195mm up to 2500mm
- Wall Mounted options; Standard Wall Brackets, Solid Wall Brackets or Stud Wall Brackets
- Floor Mounted options; Welded Feet or Cast Feet
- Standard White RAL 9016 plus 25 RAL colours, 32 special finishes & lacquered



\* Subject to correct handling, installation, water treatment and operation, Clyde Tesi radiators are guaranteed against manufacturing defects for 10 years from date of despatch.

## PACKING, HANDLING AND SITE WORK

- Radiator sections are wrapped in polyethene with polystyrene protectors. Large orders are delivered to site on pallets to facilitate handling. Accessories are delivered packed separately for fitting by the installer.
- It is important that radiators are protected from the elements during offloading and are stored in dry and adequately heated premises.
- To avoid damage to the section joints, radiators must be kept vertical after having been removed from their pallets and whilst being carried to their installation locations. They MUST NOT be carried stretcher fashion. For stock orders, factory welded and tested radiator blocks are warehouse assembled. Non-stock models are despatched as a single welded and tested block from the factory.

## TECHNICAL DATA

### PRODUCT FEATURES

- Open column radiator
- 45mm Sections
- 2 - 6 column options
- 25 Heights
- Choice of Standard / Solid Wall Brackets, Cast / Welded Feet or Stud Wall Brackets available
- Manufactured by a UNI EN ISO 9000:2000 certified company from 1.25mm thick tubular steel



### APPLICATION

- Tesi radiators are suitable for use in either open vented or sealed heating systems with a maximum operating pressure of 8 bar.

## TECHNICAL DRAWINGS & PIPE CENTRES

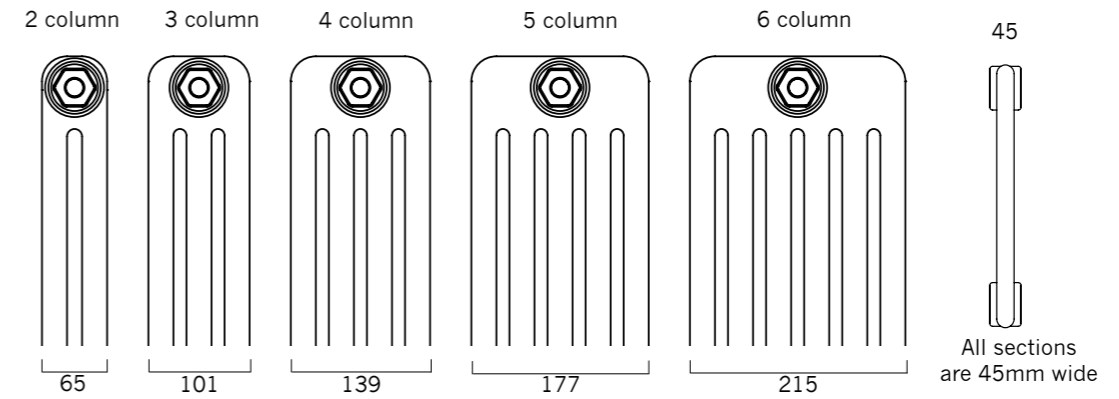

Pipe Centres for all Tesi's with Standard Wall Brackets, Solid Wall Brackets & Cast Feet;	
Pipe centres left to right = number of sections x 45mm plus 24mm (12mm each) for bushes plus valves.	
Pipe centres from wall (based on adjustable wall ties)	2 Column = 64mm to 74mm 3 Column = 82mm to 92mm 4 Column = 102mm to 112mm 5 Column = 120mm to 130mm 6 Column = 140mm to 150mm

Pipe Centres for all Tesi's with Stud Wall Brackets	
Pipe centres left to right = number of sections x 45mm plus 24mm (12mm each) for bushes plus valves.	
Pipe centres from wall (based on adjustable wall ties)	2 - 3 Column = 70mm to 80mm 4 - 5 Column = 95mm to 130mm 6 Column = 129mm to 148mm

Pipe Centres for Tesi's with Welded Feet	
Pipe centres left to right = number of sections x 45mm plus 24mm (12mm each) for bushes plus valves.	
Tesi's supplied with Welded Feet can be securely fixed to the floor, therefore allowing it to be positioned anywhere in the room. If you wish to secure the model just using Wall Ties, the pipe centre dimensions will be the same as if using Cast Feet or Wall Brackets.	

### HEAT EMISSION RATES

- ΔT50 (75°C / 65°C / 20°C)
- ΔT55.5 (82°C / 71°C / 21°C)
- ΔT60 (90°C / 70°C / 20°C)
- BS EN 442-1 conditions of ΔT50

### COMMISSIONING

- In accordance with Part L1 2006 of the Building Regulations and BS7593:1992 code of practice for the treatment of hot water and central heating systems, we strongly recommend flushing the heating system post installation of new radiators and then adding the correct quantity and type of inhibitor for use with your radiator and system to prevent corrosion. Damage caused to systems not protected by a suitable inhibitor will not be covered by manufacturer's guarantee

## SECTION EMISSION RATES AND DETAILS

Model	BS EN 442		Emission rates		Recommended Max. No. sections	Section Details						
	75/65/20°C		82/71/21°C	90/70/20°C		Overall Length L mm*	Overall height H mm	Bore centres B mm	Depth D mm	Dry weight kg	Water content litres	Surface area m²
	DT50 watts	Exponents	DT55.5 watts	DT60 watts								
TC200/2	14.9	1.25	17.0	18.7	54	45	194	127	65	0.35	0.30	0.032
TC200/3	20.3	1.29	23.2	25.7	54				101	0.51	0.40	0.047
TC200/4	26.0	1.33	29.8	33.1	54				139	0.71	0.55	0.063
TC200/5	31.7	1.35	36.5	40.5	54				177	0.88	0.62	0.079
TC200/6	37.4	1.37	43.1	48.0	54				215	1.08	0.81	0.095
TC300/2	23.4	1.24	26.7	29.4	54	45	302	235	65	0.51	0.37	0.049
TC300/3	32.5	1.25	37.0	40.8	54				101	0.77	0.52	0.072
TC300/4	42.1	1.26	48.0	52.9	54				139	1.08	0.65	0.097
TC300/5	51.4	1.28	58.7	64.9	54				177	1.32	0.84	0.121
TC300/6	60.7	1.29	69.5	76.9	54				215	1.60	1.05	0.146
TC400/2	30.1	1.25	34.3	37.8	54	45	402	335	65	0.67	0.44	0.065
TC400/3	42.0	1.26	47.9	52.9	54				101	1.02	0.64	0.096
TC400/4	54.6	1.27	62.4	68.9	54				139	1.32	0.83	0.128
TC400/5	66.5	1.29	76.1	84.2	54				177	1.72	1.03	0.160
TC400/6	78.5	1.31	90.0	99.6	54				215	2.09	1.27	0.193
TC500/2	36.7	1.25	41.8	46.1	54	45	502	435	65	0.87	0.52	0.081
TC500/3	51.4	1.27	58.7	64.8	54				101	1.37	0.75	0.119
TC500/4	66.9	1.29	76.5	84.6	54				139	1.79	0.98	0.160
TC500/5	81.3	1.31	93.2	103.2	54				177	2.14	1.22	0.200
TC500/6	95.8	1.33	110.0	122.0	47				215	2.60	1.50	0.240
TC600/2	43.2	1.26	49.2	54.3	54	45	602	535	65	1.06	0.60	0.096
TC600/3	60.6	1.28	69.2	76.5	54				101	1.49	0.86	0.143
TC600/4	79.0	1.30	90.5	100.1	54				139	2.03	1.13	0.191
TC600/5	95.9	1.32	110.1	122.0	47				177	2.63	1.41	0.239
TC600/6	112.8	1.35	129.8	144.2	39				215	3.22	1.76	0.287
TC750/2	52.9	1.27	60.4	66.7	54	45	752	685	65	1.25	0.71	0.120
TC750/3	74.4	1.30	85.2	94.2	54				101	1.89	1.03	0.178
TC750/4	96.8	1.32	111.1	123.2	46				139	2.53	1.36	0.238
TC750/5	117.4	1.35	135.0	150.0	38				177	3.17	1.69	0.298
TC750/6	137.9	1.37	159.1	177.1	32				215	3.92	2.05	0.358

SI conversion factor : 1 watt = 3.412 Btu/h

## SECTION EMISSION RATES AND DETAILS

Model	BS EN 442		Emission rates		Recommended Max. No. sections	Section Details						
	75/65/20°C		82/71/21°C	90/70/20°C		Overall Length L mm*	Overall height H mm	Bore centres B mm	Depth D mm	Dry weight kg	Water content litres	Surface area m²
	DT50 watts	Exponents	DT55.5 watts	DT60 watts								
TC900/2	62.7	1.29	71.7	79.2	54	45	902	835	65	1.49	0.83	0.143
TC900/3	87.8	1.31	100.7	111.6	50				101	2.18	1.20	0.213
TC900/4	114.3	1.34	131.5	146.0	39				139	3.10	1.59	0.285
TC900/5	138.5	1.37	159.7	177.8	32				177	3.94	1.98	0.357
TC900/6	162.6	1.40	188.1	209.8	27				215	4.53	2.45	0.429
TC1000/2	69.2	1.29	79.2	87.6	54	45	1002	935	65	1.65	0.90	0.159
TC1000/3	96.8	1.32	111.1	123.1	45				101	2.48	1.32	0.237
TC1000/4	125.9	1.34	144.8	160.8	36				139	3.30	1.74	0.317
TC1000/5	152.4	1.36	175.7	195.4	29				177	4.18	2.17	0.396
TC1000/6	178.9	1.39	206.8	230.4	24				215	5.00	2.65	0.476
TC1500/2	103.0	1.33	118.3	131.3	42	45	1502	1435	65	2.44	1.28	0.238
TC1500/3	141.7	1.33	162.8	180.6	31				101	3.65	1.89	0.355
TC1500/4	182.6	1.33	209.8	232.6	24				139	4.93	2.50	0.474
TC1500/5	220.9	1.34	253.9	281.8	20				177	6.11	3.12	0.592
TC1500/6	259.1	1.35	298.1	331.1	17				215	7.31	3.90	0.711
TC1800/2	124.3	1.33	142.8	158.4	35	45	1802	1735	65	2.91	1.53	0.285
TC1800/3	168.9	1.33	194.1	215.1	26				101	4.36	2.26	0.426
TC1800/4	216.0	1.32	248.0	274.9	20				139	5.83	2.98	0.568
TC1800/5	261.3	1.33	300.1	332.8	17				177	7.22	3.72	0.710
TC1800/6	306.5	1.33	352.2	390.9	15				215	8.64	4.62	0.853
TC2000/2	139.0	1.32	159.5	176.8	31	45	2002	1935	65	3.31	1.66	0.316
TC2000/3	187.2	1.32	214.8	238.1	23				101	4.86	2.46	0.473
TC2000/4	238.1	1.32	273.2	302.7	18				139	6.50	3.25	0.631
TC2000/5	288.0	1.32	330.6	366.6	15				177	8.04	4.07	0.789
TC2000/6	337.9	1.33	388.2	430.7	13				215	9.81	5.00	0.947
TC2500/2	177.8	1.29	203.4	225.1	25	45	2502	2435	65	3.99	2.04	0.395
TC2500/3	233.7	1.30	267.7	296.2	18				101	6.12	3.03	0.590
TC2500/4	292.8	1.31	335.5	371.5	15				139	8.10	4.02	0.788
TC2500/5	354.5	1.31	406.6	450.4	12				177	10.17	5.02	0.985
TC2500/6	416.2	1.32	477.8	529.6	11				215	12.20	6.10	1.183

SI conversion factor : 1 watt = 3.412 Btu/h

## TESI QUICK SIZING CHARTS $\Delta T50$ (75°C / 65°C / 20°C)

Model	watts per section	Radiator emission in kilowatts											
		0.6	0.8	1	1.25	1.5	1.75	2	2.5	3	4	5	6
		Nearest number of sections required											
TC200/2	14.9	40	53	—	—	—	—	—	—	—	—	—	—
TC200/3	20.3	27	36	45	—	—	—	—	—	—	—	—	—
TC200/4	26.0	21	27	34	43	51	—	—	—	—	—	—	—
TC200/5	31.7	18	24	29	37	44	52	—	—	—	—	—	—
TC200/6	37.4	16	21	26	32	39	45	52	—	—	—	—	—
TC300/2	23.4	26	35	43	54	—	—	—	—	—	—	—	—
TC300/3	32.5	19	25	31	39	46	54	—	—	—	—	—	—
TC300/4	42.1	14	19	24	30	36	42	48	—	—	—	—	—
TC300/5	51.4	12	16	20	25	30	35	40	50	—	—	—	—
TC300/6	60.7	10	13	17	21	25	29	33	42	50	—	—	—
TC400/2	30.1	20	27	33	42	50	—	—	—	—	—	—	—
TC400/3	42.0	14	18	23	29	35	40	46	—	—	—	—	—
TC400/4	54.6	11	14	18	23	27	32	36	45	54	—	—	—
TC400/5	66.5	9	12	15	18	22	26	29	37	44	—	—	—
TC400/6	78.5	8	10	13	16	19	22	25	32	38	51	—	—
TC500/2	36.7	16	21	26	32	39	45	52	—	—	—	—	—
TC500/3	51.4	11	15	18	23	28	32	37	46	—	—	—	—
TC500/4	66.9	9	12	15	18	22	26	29	36	44	—	—	—
TC500/5	81.3	7	9	12	15	18	21	24	30	36	47	—	—
TC500/6	95.8	6	8	10	13	15	18	20	25	30	40	50	—
TC600/2	43.2	13	17	22	27	32	38	43	54	—	—	—	—
TC600/3	60.6	9	13	16	20	23	27	31	39	47	—	—	—
TC600/4	79.0	7	10	12	15	18	22	25	31	37	49	—	—
TC600/5	95.9	6	8	10	12	15	17	20	25	30	40	50	—
TC600/6	112.8	5	7	8	10	13	15	17	21	25	34	42	50
TC750/2	52.9	10	14	17	21	26	30	34	43	51	—	—	—
TC750/3	74.4	8	10	13	16	19	22	25	31	38	50	—	—
TC750/4	96.8	6	8	10	12	15	17	20	25	30	40	50	—
TC750/5	117.4	5	6	8	10	12	14	16	20	24	32	40	48
TC750/6	137.9	4	6	7	9	10	12	14	17	21	28	34	41

## TESI QUICK SIZING CHARTS $\Delta T50$ (75°C / 65°C / 20°C)

Model	watts per section	Radiator emission in kilowatts											
		0.6	0.8	1	1.25	1.5	1.75	2	2.5	3	4	5	6
		Nearest number of sections required											
TC900/2	62.7	8	11	14	18	21	25	28	35	42	—	—	—
TC900/3	87.8	6	9	11	13	16	19	21	27	32	43	53	—
TC900/4	114.3	5	7	8	11	13	15	17	21	25	34	42	51
TC900/5	138.5	4	5	7	9	10	12	14	17	21	27	34	41
TC900/6	162.6	—	5	6	7	9	10	12	14	17	23	29	35
TC1000/2	69.2	8	10	13	16	19	23	26	32	39	52	—	—
TC1000/3	96.8	6	8	10	12	15	17	19	24	29	39	48	—
TC1000/4	125.9	5	6	8	10	11	13	15	19	23	31	38	46
TC1000/5	152.4	4	5	6	8	9	11	12	16	19	25	31	37
TC1000/6	178.9	—	4	5	7	8	9	11	13	16	21	26	32
TC1500/2	103.0	5	7	9	11	13	16	18	22	27	36	45	54
TC1500/3	141.7	4	5	7	8	10	12	13	16	20	26	33	40
TC1500/4	182.6	—	4	5	7	8	9	10	13	16	21	26	31
TC1500/5	220.9	—	4	4	5	7	8	9	11	13	18	22	26
TC1500/6	259.1	—	—	4	5	6	7	8	9	11	15	19	23
TC1800/2	124.3	5	6	8	9	11	13	15	19	23	30	38	46
TC1800/3	168.9	—	4	6	7	8	10	11	14	17	22	28	33
TC1800/4	216.0	—	4	4	6	7	8	9	11	13	18	22	26
TC1800/5	261.3	—	—	4	5	6	6	7	9	11	15	18	22
TC1800/6	306.5	—	—	—	4	5	6	6	8	10	13	16	19
TC2000/2	139.0	4	5	7	8	10	12	13	17	20	27	34	40
TC2000/3	187.2	—	4	5	6	8	9	10	13	15	20	25	30
TC2000/4	238.1	—	—	4	5	6	7	8	10	12	16	20	24
TC2000/5	288.0	—	—	—	4	5	6	7	8	10	13	17	20
TC2000/6	337.9	—	—	—	4	4	5	6	7	9	11	14	17
TC2500/2	177.8	—	4	5	7	8	10	11	14	16	22	27	33
TC2500/3	233.7	—	—	4	5	6	7	8	10	12	16	20	24
TC2500/4	292.8	—	—	—	4	5	6	6	8	10	13	16	19
TC2500/5	354.5	—	—	—	—	4	5	5	7	8	11	14	16
TC2500/6	416.2	—	—	—	—	4	4	5	6	7	9	12	14

## TESI QUICK SIZING CHARTS $\Delta T_{55.5}$ (82°C / 71°C / 21°C)

Model	watts per section	Radiator emission in kilowatts											
		0.6	0.8	1	1.25	1.5	1.75	2	2.5	3	4	5	6
		Nearest number of sections required											
TC200/2	17.0	35	47	—	—	—	—	—	—	—	—	—	—
TC200/3	23.2	24	31	39	49	—	—	—	—	—	—	—	—
TC200/4	29.8	18	24	30	37	45	52	—	—	—	—	—	—
TC200/5	36.5	15	21	26	32	39	45	52	—	—	—	—	—
TC200/6	43.1	14	18	23	28	34	39	45	—	—	—	—	—
TC300/2	26.7	23	30	38	47	—	—	—	—	—	—	—	—
TC300/3	37.0	16	22	27	34	41	47	54	—	—	—	—	—
TC300/4	48.0	13	17	21	26	31	37	42	52	—	—	—	—
TC300/5	58.7	10	14	17	22	26	30	35	43	52	—	—	—
TC300/6	69.5	9	12	15	18	22	25	29	36	44	—	—	—
TC400/2	34.3	17	23	29	36	44	51	—	—	—	—	—	—
TC400/3	47.9	12	16	20	25	30	35	40	50	—	—	—	—
TC400/4	62.4	9	13	16	20	24	28	32	39	47	—	—	—
TC400/5	76.1	8	10	13	16	19	23	26	32	39	51	—	—
TC400/6	90.0	7	9	11	14	17	19	22	28	33	44	—	—
TC500/2	41.8	14	18	23	28	34	39	45	—	—	—	—	—
TC500/3	58.7	10	13	16	20	24	28	32	40	48	—	—	—
TC500/4	76.5	8	10	13	16	19	22	25	32	38	51	—	—
TC500/5	93.2	6	8	10	13	15	18	21	26	31	41	52	—
TC500/6	110.0	5	7	9	11	13	15	18	22	26	35	44	53
TC600/2	49.2	11	15	19	23	28	33	38	47	—	—	—	—
TC600/3	69.2	8	11	14	17	20	24	27	34	41	—	—	—
TC600/4	90.5	6	9	11	13	16	19	21	27	32	43	54	—
TC600/5	110.1	5	7	9	11	13	15	17	22	26	35	44	52
TC600/6	129.8	4	6	7	9	11	13	15	18	22	29	37	44
TC750/2	60.4	9	12	15	19	22	26	30	37	45	—	—	—
TC750/3	85.2	7	9	11	14	16	19	22	27	33	44	—	—
TC750/4	111.1	5	7	9	11	13	15	17	22	26	35	43	52
TC750/5	135.0	4	6	7	9	11	12	14	18	21	28	35	42
TC750/6	159.1	4	5	6	8	9	11	12	15	18	24	30	36

## TESI QUICK SIZING CHARTS $\Delta T_{55.5}$ (82°C / 71°C / 21°C)

Model	watts per section	Radiator emission in kilowatts											
		0.6	0.8	1	1.25	1.5	1.75	2	2.5	3	4	5	6
		Nearest number of sections required											
TC900/2	71.7	7	10	12	15	18	22	25	31	37	49	—	—
TC900/3	100.7	6	7	9	12	14	16	19	23	28	37	46	—
TC900/4	131.5	4	6	7	9	11	13	15	18	22	29	37	44
TC900/5	159.7	4	5	6	7	9	10	12	15	18	24	30	36
TC900/6	188.1	—	4	5	6	8	9	10	13	15	20	25	30
TC1000/2	79.2	7	9	11	14	17	20	23	28	34	45	—	—
TC1000/3	111.1	5	7	8	11	13	15	17	21	25	34	42	51
TC1000/4	144.8	4	5	7	8	10	12	13	17	20	27	33	40
TC1000/5	175.7	—	4	5	7	8	10	11	14	16	22	27	33
TC1000/6	206.8	—	4	5	6	7	8	9	11	14	18	23	28
TC1500/2	118.3	5	6	8	10	12	14	16	19	23	31	39	47
TC1500/3	162.8	—	5	6	7	9	10	12	14	17	23	29	35
TC1500/4	209.8	—	4	5	6	7	8	9	11	14	18	23	27
TC1500/5	253.9	—	—	4	5	6	7	8	10	12	15	19	23
TC1500/6	298.1	—	—	—	4	5	6	7	8	10	13	17	20
TC1800/2	142.8	4	5	7	8	10	12	13	17	20	26	33	40
TC1800/3	194.1	—	4	5	6	7	8	10	12	15	19	24	29
TC1800/4	248.0	—	—	4	5	6	7	8	10	12	15	19	23
TC1800/5	300.1	—	—	—	4	5	6	6	8	10	13	16	19
TC1800/6	352.2	—	—	—	—	4	5	6	7	8	11	14	17
TC2000/2	159.5	4	5	6	7	9	10	12	15	18	24	29	35
TC2000/3	214.8	—	—	4	5	7	8	9	11	13	17	22	26
TC2000/4	273.2	—	—	—	4	5	6	7	9	10	14	17	21
TC2000/5	330.6	—	—	—	4	4	5	6	7	9	12	15	18
TC2000/6	338.2	—	—	—	—	4	4	5	6	8	10	13	15
TC2500/2	203.4	—	4	5	6	7	8	9	12	14	19	24	28
TC2500/3	267.7	—	—	—	4	5	6	7	9	10	14	17	21
TC2500/4	335.5	—	—	—	4	4	5	6	7	8	11	14	17
TC2500/5	406.6	—	—	—	—	4	4	5	6	7	10	12	14
TC2500/6	477.8	—	—	—	—	—	4	4	5	6	8	10	12

## Tesi QUICK SIZING CHARTS $\Delta T_{60}$ (90°C / 70°C / 20°C)

Model	watts per section	Radiator emission in kilowatts											
		0.6	0.8	1	1.25	1.5	1.75	2	2.5	3	4	5	6
		Nearest number of sections required											
TC200/2	18.7	32	42	53	—	—	—	—	—	—	—	—	—
TC200/3	25.7	21	28	36	44	53	—	—	—	—	—	—	—
TC200/4	33.1	16	22	27	34	41	47	54	—	—	—	—	—
TC200/5	40.5	14	19	23	29	35	41	47	—	—	—	—	—
TC200/6	48.0	12	16	20	25	31	36	41	51	—	—	—	—
TC300/2	29.4	21	27	34	43	51	—	—	—	—	—	—	—
TC300/3	40.8	15	20	24	31	37	43	49	—	—	—	—	—
TC300/4	52.9	11	15	19	24	28	33	38	47	—	—	—	—
TC300/5	64.9	9	12	16	20	23	27	31	39	47	—	—	—
TC300/6	76.9	8	11	13	16	20	23	26	33	39	53	—	—
TC400/2	37.8	16	21	26	33	39	46	53	—	—	—	—	—
TC400/3	52.9	11	15	18	23	27	32	36	45	—	—	—	—
TC400/4	68.9	9	11	14	18	21	25	29	36	43	—	—	—
TC400/5	84.2	7	9	12	15	17	20	23	29	35	46	—	—
TC400/6	99.6	6	8	10	12	15	17	20	25	30	40	50	—
TC500/2	46.1	12	16	20	25	31	36	41	51	—	—	—	—
TC500/3	64.8	9	12	15	18	22	25	29	36	44	—	—	—
TC500/4	84.6	7	9	12	14	17	20	23	29	35	46	—	—
TC500/5	103.2	6	7	9	12	14	16	19	23	28	37	47	—
TC500/6	122.0	5	6	8	10	12	14	16	20	24	32	40	48
TC600/2	54.3	10	14	17	21	25	30	34	42	51	—	—	—
TC600/3	76.5	7	10	12	15	19	22	25	31	37	49	—	—
TC600/4	100.1	6	8	10	12	15	17	19	24	29	39	49	—
TC600/5	122.0	5	6	8	10	12	14	16	20	24	31	39	47
TC600/6	144.2	4	5	7	8	10	12	13	17	20	26	33	40
TC750/2	66.7	8	11	13	17	20	24	27	34	40	54	—	—
TC750/3	94.2	6	8	10	12	15	17	20	25	30	40	49	—
TC750/4	123.2	5	6	8	10	12	14	16	20	23	31	39	47
TC750/5	150.0	4	5	6	8	10	11	13	16	19	25	32	38
TC750/6	177.1	—	4	5	7	8	10	11	14	16	22	27	33

## Tesi QUICK SIZING CHARTS $\Delta T_{60}$ (90°C / 70°C / 20°C)

Model	watts per section	Radiator emission in kilowatts											
		0.6	0.8	1	1.25	1.5	1.75	2	2.5	3	4	5	6
		Nearest number of sections required											
TC900/2	79.2	7	9	11	14	17	19	22	28	33	44	—	—
TC900/3	111.6	5	7	8	11	13	15	17	21	25	34	42	50
TC900/4	146.0	4	5	7	8	10	12	13	17	20	27	33	40
TC900/5	177.8	—	4	5	7	8	9	11	14	16	22	27	32
TC900/6	209.8	—	4	5	6	7	8	9	11	14	18	23	27
TC1000/2	87.6	6	8	10	13	15	18	20	25	31	41	51	—
TC1000/3	123.1	5	6	8	10	11	13	15	19	23	31	38	46
TC1000/4	160.8	4	5	6	8	9	11	12	15	18	24	30	36
TC1000/5	195.4	—	4	5	6	7	9	10	12	15	20	25	30
TC1000/6	230.4	—	—	4	5	6	7	8	10	12	17	21	25
TC1500/2	131.3	4	6	7	9	11	12	14	18	21	28	35	42
TC1500/3	180.6	—	4	5	7	8	9	10	13	16	21	26	31
TC1500/4	232.6	—	—	4	5	6	7	8	10	12	17	21	25
TC1500/5	281.8	—	—	—	4	5	6	7	9	10	14	17	21
TC1500/6	331.1	—	—	—	4	4	5	6	7	9	12	15	18
TC1800/2	158.4	4	5	6	7	9	10	12	15	18	24	30	36
TC1800/3	215.1	—	4	4	5	7	8	9	11	13	18	22	26
TC1800/4	274.9	—	—	—	4	5	6	7	9	10	14	17	21
TC1800/5	332.8	—	—	—	4	4	5	6	7	9	12	15	17
TC1800/6	390.9	—	—	—	—	4	4	5	6	8	10	13	15
TC2000/2	176.8	—	4	5	7	8	9	11	13	16	21	27	32
TC2000/3	238.1	—	—	4	5	6	7	8	10	12	16	20	24
TC2000/4	302.7	—	—	—	4	5	5	6	8	9	13	16	19
TC2000/5	366.6	—	—	—	—	4	5	5	7	8	11	13	16
TC2000/6	430.7	—	—	—	—	—	4	5	6	7	9	11	14
TC2500/2	225.1	—	—	4	5	6	8	9	11	13	17	21	26
TC2500/3	296.2	—	—	—	4	5	6	6	8	9	13	16	19
TC2500/4	371.5	—	—	—	—	4	4	5	6	8	10	13	15
TC2500/5	450.4	—	—	—	—	—	4	4	5	6	9	11	13
TC2500/6	529.6	—	—	—	—	—	—	4	5	6	7	9	11

## FIXING AND ENCLOSURES

It is recommended that radiators are installed with a minimum gap of 97mm above floor level. A full width window sill above the radiator extending the depth of the radiator will reduce emission rates by approximately 4%.

Boxing of radiator or the use of decorative enclosures will reduce emission rate by upwards of 15%, according to the design of the boxing. Any restriction of the free flow of air over the radiator surface is detrimental to convected heat emission. Obscuring the front surface of the radiator eliminates the beneficial effect of radiated heat.

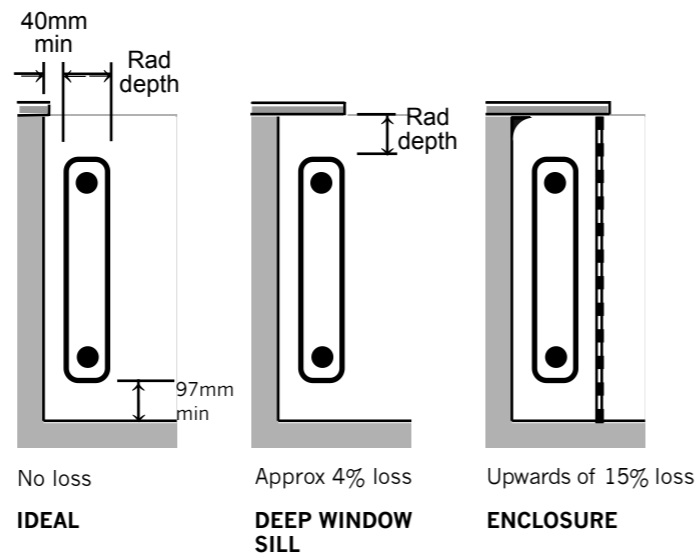

## FIXING ARRANGEMENTS, WALL BRACKETS AND FLOOR MOUNTS

Always use Clyde radiator brackets, supports and ties. Clyde offer 5 different types of mounting options; standard wall brackets, solid wall brackets, welded feet, cast feet & stud wall brackets (see drawings below), all are supplied with appropriate wall ties. If the wall on which the radiators are being installed is solid and sound, then wall mounting using standard wall brackets and ties is recommended. If the wall is generally unsound, a studwork partition wall or built of low density cellular blocks, welded feet or cast feet with wall ties are recommended.

If the walls are not sound or are partition walls and the radiator is to be wall mounted, there must be studwork capable of supporting the weight of the filled radiator. Special arrangements may be necessary for partition walling, dry lined and composite walls (eg flint aggregate) which are commonly encountered in period restoration projects. Pipework should never be used to provide support for the radiator.

Assembling instructions are supplied with all Clyde radiator wall brackets, floor mounts and wall ties.

All screw fixes and wall plugs must be proprietary fittings selected by the installer to be suitable for the construction and fabric of the wall to which the supports, mounts and stays are being fixed. Fibre or ceramic plug materials should not be used as these degrade in time and become unreliable.

### Standard Wall Bracket

No. of Sections	Column Range	No. of Brackets
2 - 20	2 - 6	2
21 - 30	2 - 6	3
31 - 40	2 - 6	4
41 - 54	2 - 6	5+

minimum 100mm

### Cast Feet

No. of Sections	Column Range	No. of Feet
2 - 20	2 - 6	2
21 - 30	2 - 6	3
31 - 40	2 - 6	4
41 - 54	2 - 6	5

100mm

### Solid Wall Bracket

No. of Sections	Column Range	No. of Brackets
2 - 20	2 - 6	2
21 - 30	2 - 6	4
31 - 40	2 - 6	4
41 - 54	2 - 6	6

minimum 100mm

### Welded Feet

No. of Sections	No. of Feet
Up to 20 sections	2
21-39 (odd number of sections)	3
22-54 (even number of sections)	4
41-53 (odd number of sections)	5

97mm

### Stud Wall Bracket

No. of Sections	Column Range	No. of Brackets
2 - 20	2 - 6	4
21 - 30	2 - 6	6
31 - 40	2 - 6	8
41 - 54	2 - 6	10

minimum 100mm

### Wall Tie

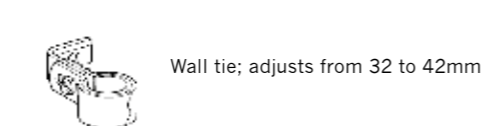

## CONNECTIONS

A set of connection fittings is provided for each radiator.

Each set comprises :

2 x R1¼ x R½ pipe connection bushes

1 x R1¼ plug (RH thread)

1 x R1¼ vent bush (LH thread) and R½ vent valve.

Radiators are normally installed with either BOE (bottom opposite end) or TBOE (top & bottom opposite end) connections. Unless notified at time of order, radiators are supplied with ½" BOE connections as standard. If you require different connections please contact us on 01342 305550 for more information.

For installations with BOE connections, a diverter (supplied) should be fitted at the inlet connection for all radiators.

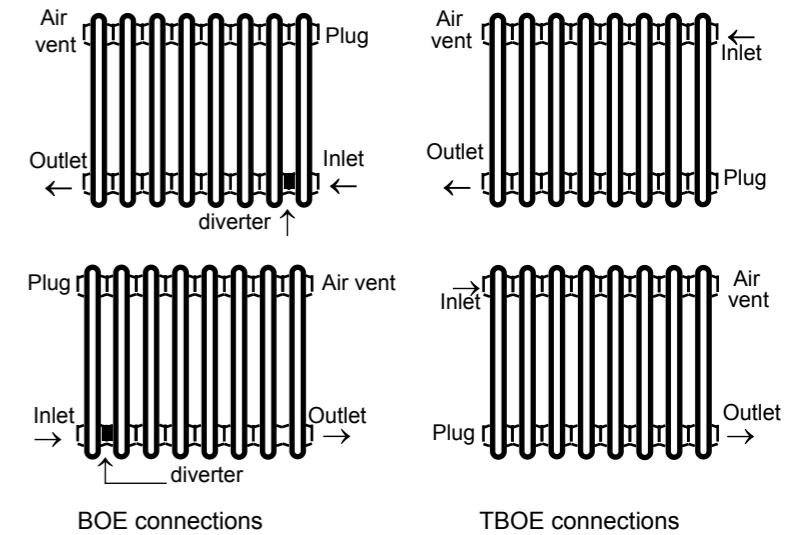

**IMPORTANT : Inspect the radiator for any damage before installing and filling with water.**

## CARRYING RADIATORS

Steel Multi Column radiators are heavy. Always provide sufficient manpower to make carrying safe. Incorrect handling of radiator blocks can cause water leaks from section joints. Lift the radiator blocks in the centre to bring them to the vertical position before lifting and carrying. Never carry radiators stretcher fashion.

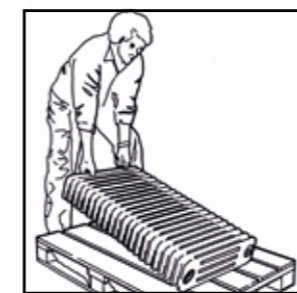

**DO NOT**  
Lift from one end

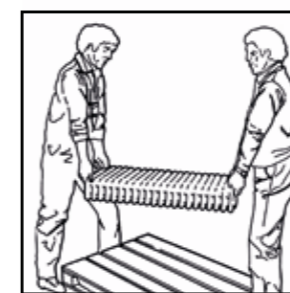

**DO NOT**  
Carry radiators flat

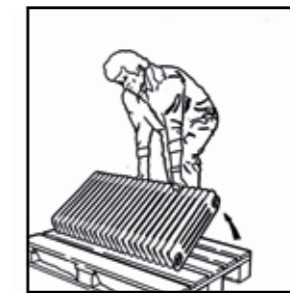

**ALWAYS**  
Lift in centre

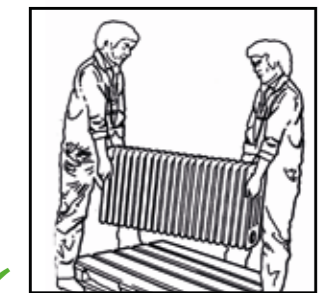

**ALWAYS**  
Keep sections vertical



## TESI COLOUR OPTIONS

If you are looking to have your Tesi radiator in an alternative colour we offer the following RAL colour options, please specify chosen colour at time of order.



To discuss a quotation for other colours outside of the above range please call 01342 305550

## TESI COLOUR OPTIONS

There are 33 classic colours to choose from including: metallics, mottled, textured effects and bare metal lacquer finishes, for more information please call our Customer Service team on 01342 305550.



## BARE METAL LACQUER

This finish highlights the raw basic steel product showcasing the manufacturing marks created by the processes of welding and sanding to deliver an industrial look. Each radiator will be unique, with the random position of the weld lines on the column tubes and the level of the final sanding. The clear lacquer allows these characteristics to be the hero and maintains the natural steel finish.



## VALVES

Choose one of our TRV valves to complement your steel multi column radiator, see below and right for details

### AYR TRV

- ▶ Pipe centres allow an extra 70mm in total
- ▶ Ayr valves are Bi-directional.
- ▶ Available in White or Chrome
- ▶ R½ x 15mm compression in angled or straight
- ▶ Supplied in pairs of one thermostatic valve & one lockshield



## VALVES

Choose one of our TRV valves to complement your steel multi column radiator, see below for details

### TRADITIONAL XL TRV

- ▶ Height of Wheelhead 160mm
- ▶ Available in Chrome, Nickel & Antique Brass supplied with a Black top
- ▶ Available in Antique Copper & Polished Brass supplied with a Walnut top
- ▶ For angled valve allow an extra 120mm in total
- ▶ Traditional XL TRV's are not Bi-directional
- ▶ Supplied in pairs of one thermostatic valve & one lockshield
- ▶ R½ x 15mm compression angled valves



### ESTATE TRV

- ▶ Height of Wheelhead 127mm
- ▶ Available in Brass & Chrome
- ▶ Straight or Angled
- ▶ For angled valves allow an extra 80mm in total
- ▶ Estate TRV's are not Bi-directional
- ▶ Supplied in pairs of one thermostatic valve & one lockshield
- ▶ R½ x 15mm compression angled valves



## OTHER CLYDE PRODUCTS

### Clyde Radiators

#### COMMERCIAL HEATING SOLUTIONS

- 4 Flat Panel radiators
- Lightweight & Efficient Sectional Aluminum
- Sectional Cast Iron in 4 styles
- 2 Bespoke LST options, made to specification

- Trench: Practical aluminium convector for underfloor heating
- Mini: Aluminium and copper convector, in steel casing with aluminium grille



[www.clyderadiators.co.uk](http://www.clyderadiators.co.uk)

### TRADITIONAL TRV

- ▶ Height of Wheelhead 115mm
- ▶ Chrome and Nickel finishes supplied with a Black top
- ▶ Antique Copper, Antique Brass and Polished Brass supplied with a Walnut top
- ▶ For angled valve allow an extra 90mm in total
- ▶ Traditional TRV's are not Bi-directional
- ▶ Supplied in pairs of one thermostatic valve & one lockshield
- ▶ R½ x 15mm compression angled valves

